

Shower & Bath

Amber

Comfort, hygiene and safety for perfect patient and personal care.

Electric height adjustable wall shower stretcher

REF. 7753.00

The shower stretcher enables persons with a poor sitting balance to be ergonomically washed under running water. The shower stretcher is attractive, user-friendly, easy-to-maintain, has an extensive height range. The shower stretcher is safe for both the patient and the user. The wall-mounted unit is height adjustable and has a multi-functional design. By positioning this highly versatile shower stretcher to the correct height, transfers can be easily made from other aids such as beds, stretchers, shower seats and wheelchairs.



REVAL
SUSTAINABLE WELL-BEING

Shower & Bath

Amber



UNIQUE FEATURES

- User friendly.
- Transfer easy.
- Easy to clean.
- Rilsan coating, shockproof.
- Silent adjustable height.
- Small size.

Electric height adjustable wall shower stretcher

REF. 7753.00

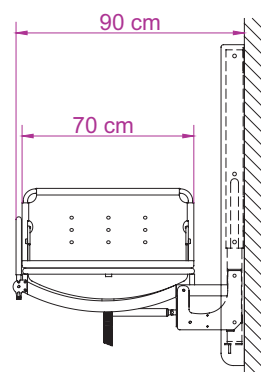
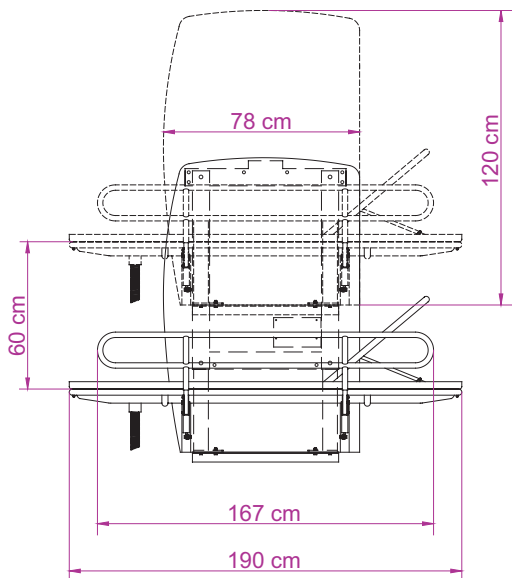

DESCRIPTION:

- Wall frame: steel, electrolytically galvanised.
- 1 folding safety barrier.
- 1 adjustable backrest.
- Rilsan coating, shockproof.
- Stainless steel hinges and screws.
- Hi/Lo functions by 24v electric jack.
- Support in semi-stiff punched PVC.
- Drain by collection tub with draining pipe.

HI/LO JACK:

- Voltage / Power / IP: 24 Vdc / 120 W / IP66

CONFORMITY:

- 93/42/CEE (Medical Devices Directive)
- ISO 10535:2006 (Hoists for the Transfer of Disabled Persons)
- ISO 14971:2007 (Risk Management for Medical Devices)

BATHROOM REQUIREMENTS:

(to consult the technical needs sheet)

- 230V power supply.
- 30mA differential switch.
- Universal socket (min. IP55).
- Ø40mm discharge available in proximity to shower stretcher.
- No obstacles on wall.

PERFORMS:

- Maximum patient weight : 150 kg
- Lifting capacity : 135 kg
- Weight of the complete unit : 85 kg
- Lifting range : 60 cm
- Speed : 14 mm/s at maximum load.
- Lowest reclining position : 40 - 50 cm above the floor